

DE Series

PCB mount ultra compact, regulated, high voltage DC-DC converter



56 standard products

- Reference: see chart for complete reference
- Vin: 15Vdc or 24Vdc
- Vout: 0 to 1kV, 2kV, 4kV or 6kV
- Pout: 1W, 2W, 4W or 6W



General Description

The DE Series is particularly adapted to controlling photonic detectors that need high bias voltages and currents. Industrials, integrators and researchers will benefit from the units small size, lightweight design, excellent voltage regulation and reduced residual undulation.

Small height and lightweight	Tight line / load regulation	Low ripple (0.02% p. to p.)
PCB flat mounting	Output current limit protection	Low noise due to metal shielding
Adjustable from 0 to full output	Auto-inhibition in case of overheat	Voltage and current buffered monitoring

Parameters	Specifications
Input voltage Vin (pins 2 & 3)	15Vdc \pm 1.5Vdc or 24Vdc \pm 2Vdc, according to type
Input current	Example for a 15Vdc, output 6000V, 1mA model: inhibition mode: 27mA at no load & HV = 6000V: 46mA at full load: 260mA
HV output Vout (pin 8)	0 to 1000V through 0 to 6000V according to type
Polarity	Fixed positive [DEP] or negative [DEN]; refer to the Selection Guide
HV setting (pins 4 & 6)	<ul style="list-style-type: none">• Option 1: via external voltage source 0/ 5V \pm0.1 % at full scale, and input impedance = 94kΩ• Option 2: via external voltage source 0/10V \pm0.1 % at full scale, and input impedance = 187kΩ
Max. output current Iout	Limited to 110 % of nominal current; refer to the Selection Guide
Load voltage regulation	\pm 0,01 % of full output voltage for no load to full load
Line voltage regulation	<0,02 % of full output voltage over specified input voltage range
Residual ripple	0,005 % peak-to-peak at full load
Temperature coefficient	100ppm/ $^{\circ}$ C
Output HV monitoring (pin 7) (still operating in inhibition mode)	<ul style="list-style-type: none">• Option 1: analog 0/+ 5V buffered output signal, accuracy \pm0.2 %• Option 2: analog 0/+10V buffered output signal, accuracy \pm0.2 % Output impedance = 1k Ω Temperature coefficient: 100ppm/ $^{\circ}$ C



DE Series

PCB mount ultra compact, regulated, high voltage DC-DC converter

Parameters	Specifications
Output current monitoring (pin 5) (still operating in inhibition mode)	<ul style="list-style-type: none">• Option1: analog 0/+ 5V buffered output signal, accuracy $\pm 2\%$• Option2: analog 0/+10V buffered output signal, accuracy $\pm 2\%$ Output impedance = 1k Ω Temperature coefficient : 100ppm/ $^{\circ}\text{C}$
HV power ON/OFF	To disable (opened remote interlock) or enable (closed remote interlock)
Operating temperature	Refer to Derating Curve
Storage temperature	-10 $^{\circ}\text{C}$ to +70 $^{\circ}\text{C}$
Safeguards	<ul style="list-style-type: none">• Protected against reverse Vin• Soft start feature: the start is guaranteed with no overshoot• Auto inhibition if Tcase > 75$^{\circ}\text{C}$• HV setting internally limited to 10.6V for the 10V version and to 5.3V for the 5V version

Main Applications

- Avalanche Photo Diodes (APD)
- Electrostatic Chuck (E-chuck)
- E-Beam Lithography and Welding
- Focused Ion Beam (FIB)
- Gas Chromatography
- Geiger Muller Tubes (GM Tubes)
- General Laboratory
- High Voltage Testing
- Image Intensifiers (II)
- Insulator Testing
- Lithography
- Microchannel Plates (MCP)
- Photodiodes (PD)
- Photomultiplier Tubes (PMT)
- Scanning Electron Microscopes
- Spectrometer

Pin Connections

Inhibition input	1. ON/OFF
Line input	2. 0V supply 3. Vin
HV setting	3. 0V signal 4. Control input
HV monitoring	5. Current monitoring 6. Voltage monitoring
HV output	7. Vout



DE Series

PCB mount ultra compact, regulated, high voltage DC-DC converter

Package Configuration	
Case material	Tin steel plate Thickness 0.5 mm
Case dimensions LxHxW	63.5 x 13.0 x 44.0 mm
Pins	0.63 x 0.63 mm square pins Length : > 6 mm, Spacing: 2.54 mm
Weight	72 g
Insulation	Fully potted in an epoxy resin

Marking

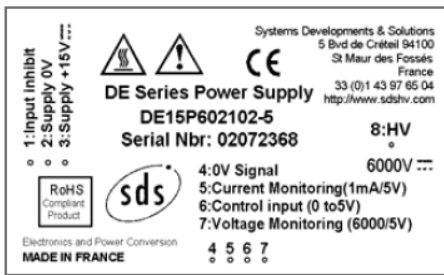

Derating Curve

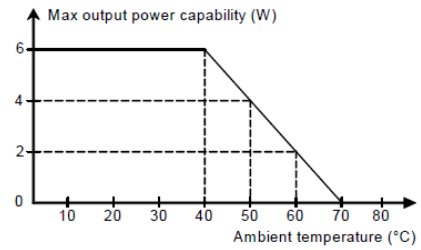

Under certain environmental conditions, and for some configurations, the installation of a heatsink might be necessary

Mechanical dimensions

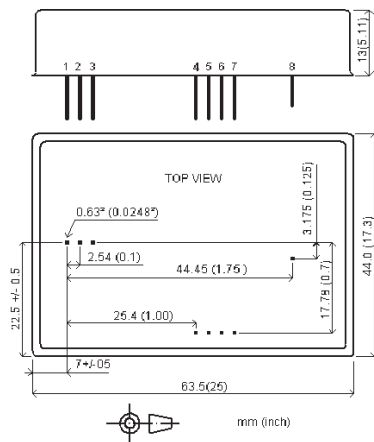

Functional diagram

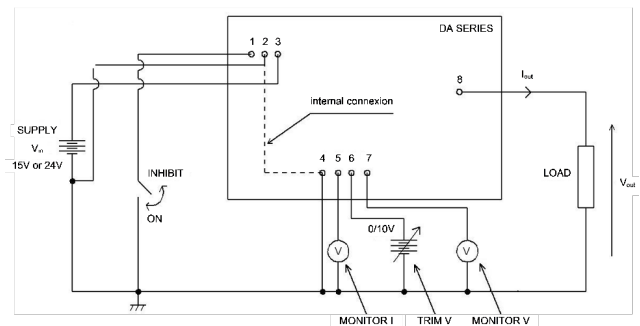

DE Series

PCB mount ultra compact, regulated, high voltage DC-DC converter

Ordering information

Model	Name of the series	DE
Vin	15Vdc nominal	15
	24Vdc nominal	24
Polarity	Positive output voltage	P
	Negative output voltage	N
Vout	Output voltage	See ordering code
Pout	Output in Watt	See ordering code
Ctr., Monitor	+5Vdc control reference voltage	C5
	+10Vdc control reference voltage	C10

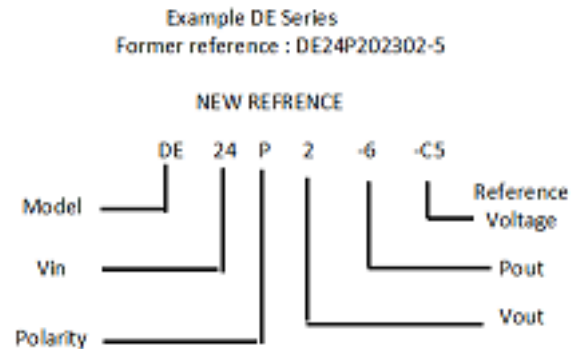

Ordering voltage and power code

- The power supplies have a 6-element order code:
 - The first 2 letters refer to the series
 - The first 2 digits indicate the value of the input voltage
 - the following letter indicates the polarity
 - the following number indicates the output voltage in kV
 - the last digit indicates the power in Watt
 - the last digit preceded by the letter «C» refers to the output HV mono-

Ordering example

The ordering code of a +2kV@6W psu under 24Vdc and with 0/5V controls is: DE24P2-6-C5

DE Series overview

		Pout (W)			
		1	2	4	6
Vout (Vdc)	1000	-	-	-	DExx6-1-x
	2000	-	-	-	DExx6-2-x
	4000	-	-	-	DExx6-4-x
	6000	DExx6-1-x	DExx6-2-x	DExx6-3-x	DExx6-6-x

cf. DA Series

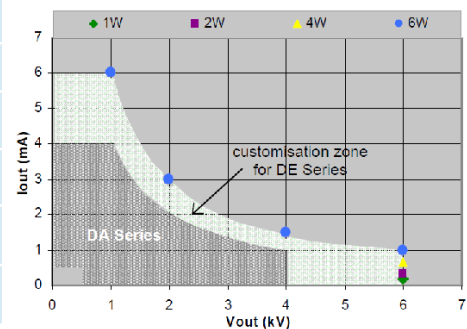

DE Series

PCB mount ultra compact, regulated, high voltage DC-DC converter

DE Series selection guide

Vout	Iout/Pout	Vin	Polarity	HV monitoring	Former reference	NEW REFERENCE
6000V	1.0mA/6W	15V	+	0/10V	DE15P602102-10	DE15P6-6-C10
				0/5V	DE15P602102-5	DE15P6-6-C5
			-	0/10V	DE15N602102-10	DE15N6-6-C10
				0/5V	DE15N602102-5	DE15N6-6-C5
		24V	+	0/10V	DE24P602102-10	DE24P6-6-C10
				0/5V	DE24P602102-5	DE24P6-6-C5
	-	0/10V	DE24N602102-10	DE24N6-6-C10		
		0/5V	DE24N602102-5	DE24N6-6-C5		
	0.66mA/4W	15V	+	0/10V	DE15P602661-10	DE15P6-4-C10
				0/5V	DE15P602661-5	DE15P6-4-C5
			-	0/10V	DE15N602661-10	DE15N6-4-C10
				0/5V	DE15N602661-5	DE15N6-4-C5
		24V	+	0/10V	DE24P602661-10	DE24P6-4-C10
				0/5V	DE24P602661-5	DE24P6-4-C5
	-	0/10V	DE24N602661-10	DE24N6-4-C10		
		0/5V	DE24N602661-5	DE24N6-4-C5		
	0.33mA/2W	15V	+	0/10V	DE15P602331-10	DE15P6-2-C10
				0/5V	DE15P602331-5	DE15P6-2-C5
			-	0/10V	DE15N602331-10	DE15N6-2-C10
				0/5V	DE15N602331-5	DE15N6-2-C510
		24V	+	0/10V	DE24P602331-10	DE24P6-2-C10
				0/5V	DE24P602331-5	DE24P6-2-C5
	-	0/10V	DE24N602331-10	DE24N6-2-C10		
		0/5V	DE24N602331-5	DE24N6-2-C5		
0.16mA/1W	15V	+	0/10V	DE15P602161-10	DE15P6-1-C10	
			0/5V	DE15P602161-5	DE15P6-1-C5	
		-	0/10V	DE15N602161-10	DE15N6-1-C10	
			0/5V	DE15N602161-5	DE15N6-1-C5	
	24V	+	0/10V	DE24P602161-10	DE24P6-1-C10	
			0/5V	DE24P602161-5	DE24P6-1-C5	
-	0/10V	DE24N602161-10	DE24N6-1-C10			
	0/5V	DE24N602161-5	DE24N6-1-C5			

DE Series

PCB mount ultra compact, regulated, high voltage DC-DC converter

DE Series selection guide (continued)

Vout	Iout/POut	Vin	Polarity	Ctrl. Monitor	Model			
4000V	1.5mA/6W	15V	+	0/10V	DE15P402152-10	DE15P4-6-C10		
				0/5V	DE15P402152-5	DE15P4-6-C5		
			-	0/10V	DE15N402152-10	DE15N4-6-C10		
				0/5V	DE15N402152-5	DE15N4-6-C5		
		24V	+	0/10V	DE24P402152-10	DE24P4-6-C10		
				0/5V	DE24P402152-5	DE24P4-6-C5		
			-	0/10V	DE24N402152-10	DE24N4-6-C10		
				0/5V	DE24N402152-5	DE24N4-6-C5		
2000V	3.0mA/6W	15V	+	0/10V	DE15P202302-10	DE15P2-6-C10		
				0/5V	DE15P202302-5	DE15P2-6-C5		
			-	0/10V	DE15N202302-10	DE15N2-6-C10		
				0/5V	DE15N202302-5	DE15N2-6-C5		
		24V	+	0/10V	DE24P202302-10	DE24P2-6-C10		
				0/5V	DE24P202302-5	DE24P2-6-C5		
			-	0/10V	DE24N202302-10	DE24N2-6-C10		
				0/5V	DE24N202302-5	DE24N2-6-C5		
		1000V	6.0mA/6W	15V	+	0/10V	DE15P102602-10	DE15P1-6-C10
						0/5V	DE15P102602-5	DE15P1-6-C5
					-	0/10V	DE15N102602-10	DE15N1-6-C10
						0/5V	DE15N102602-5	DE15N1-6-C5
24V	+			0/10V	DE24P102602-10	DE24P1-6-C10		
				0/5V	DE24P102602-5	DE24P1-6-C5		
	-			0/10V	DE24N102602-10	DE24N1-6-C10		
				0/5V	DE24N102602-5	DE24N1-6-C5		

Other output voltages and output currents are available upon request.

Do not hesitate to ask us about any parameter you would like to see changed for your application.



This High Voltage power supply satisfies the requirements of EC Directives Safety.

Non contractual document.
All specifications are subject to change without notice.

RevA 05/10

